

- SMS and GSM/GPRS packet transmission
- Integral GSM 850/900/1800/1900 modem with autonomous GPRS login procedures
- 6 binary/counter inputs for potential free contacts (for instance, pulse outputs from flow meters)
- 2 analogue inputs 0-5 VDC with configurable alarm thresholds and hysteresis
- Built in pressure gauge 0 ... 10 Bar (other ranges optional)
- 2 controlling outputs
- Latched 0-5 VDC voltage supply for external analogue sensors
- Shock sensors (detecting intrusion)
- Intelligent data logger (4 MB Flash memory-max. 10 000 records)
- Configurable schedules and events initiating measurements and data transmission
- Real Time Clock RTC
- External power supply 7-30 VDC (alkaline or lithium batteries, accumulators, solar panels, permanent supply)
- Intelligent power management
- USB Port (IP68) for local configuration
- IP68 cabinet and connectors, circuits molded in protective gel
- Optional GPS receiver
- SMB IP-68 antenna socket



- Operating temperature -20°...+55 °C
- Intuitive, user friendly configuration and communication applications.
- Application for remote control via GPRS network
- Remote firmware updates

MT-723 PT logger and transmission module has highest grade of protection in harsh environment. As other modules of MT family it is known for innovative design, advanced technologies and for ease of configuration and integration in data collection and processing systems. Spontaneous data transmission on event occurrence allow minimizing transmission costs and energy consumption thus prolonging battery life time. However it is possible to set up device to stay online permanently or for desired time thus allowing to poll both current, logged or both types of data asynchronously from module. Simple, robust design enclosed in polycarbonate housing with IP-68 ingress protection class allows installation in harsh environment where there is no supply of electricity (like for instance water supply systems measuring chambers).

The module may be powered from alkaline batteries, lithium batteries, lead batteries, solar panels or from power lines.

The level of power supply is constantly monitored and reported along with measurement data. Internal lithium battery secures pulse counting on inputs I1...I6 secures RTC clock function and alarm transmission in case of main supply failure.

MT-723 PT is equipped with: 6 binary/counter inputs (adapted to work with potential free contacts for water consumption meter), 2 analogue inputs allowing measuring various parameters like pressure, temperature, level, humidity. The module has a pressure gauge with quick coupling allowing comfortable connection with pressure hose. Extremely low power consumption is achieved by deactivating GPRS/GSM modem when not transmitting and using latched power supply output for external analogue sensors or for controlling power supply to external equipment only for measuring time. Measurement data may be registered with precise time stamp in non volatile Flash memory either by schedule or on event.

The module can beyond measuring issue alerts in case of mechanical shock, submersion, unauthorized chamber opening, lack of flow, too high flow, high pressure, high level, temperature, humidity e.t.c.

The configuration environment and communication application with open OPC/ODBC/CSV interfaces and an application for remote management via GPRS network comes free of charge with the purchase of the module. The user may unrestricted use new firmware versions thanks to capability of remote upgrading.



General

Dimensions (length x width x height)	80x170x65 mm
Weight	870 g
Mounting type	4 holes
Operating temperature	-20 ... +55 °C
Protection class	IP68

GSM/GPRS Modem

Modem type	WAVECOM WIRELESS CPU
GSM	Quad Band (850/900/1800/1900)
Frequency range:	
GSM 850	Transmitter: 824MHz – 849 MHz Receiver: 869 MHz – 894 MHz
EGSM 900	Transmitter: 880 MHz – 915 MHz Receiver: 925 MHz – 960 MHz
DCS 1800	Transmitter: 1710 MHz – 1785 MHz Receiver: 1805 MHz – 1880 MHz
PCS 1900	Transmitter: 1850 MHz – 1910 MHz Receiver: 1930 MHz – 1990 MHz
Transmitter peak power GSM850/EGSM900	33 dBm (2W) – class 4 station
Transmitter peak power DCS1800/PCS1900	30 dBm (1W) – class 1 station
Modulation	0,3 GMSK
Channel spacing	200 kHz
Antenna	50Ω

Power

Power voltage range	7 – 30 VDC
Average current in sleep mode (for 12 V)	<250 μA
Average current when transmitting data (for 12 V)	25 mA
Maximum peak current when transmitting data (for 12 V)	500 mA

Analog inputs AN1...AN3 (voltage, differential)

Input signal range	0 ... 5,0 V
Input resistance	>600 kΩ typ.
Resolution	12 bits
Accuracy in full operating temperature range	± 0,3 %
Accuracy in 25 °C	± 0,1 %

Integrated pressure gauge AN1

Measurement range	0 ... 10 Bar
Temperature of medium	0 ... 80 °C
Accuracy	0,5 %

Binary inputs I1...I6/counter inputs I1...I5

Contact polarization	3 V
Counting frequency for counter inputs	250 Hz max.
Minimal pulse length for counter inputs	2 ms
Minimal pulse length for binary inputs	0,1 s

NMOS outputs Q1, Q2

Maximum voltage	30 V
Maximum current	250 mA
Switch off current	< 50 μA
Resistance	1Ω

Configurable voltage output

Voltage range	0 ... 5,0 V
Resolution	0,1 V
Accuracy	2 %
Maximum current	50 mA

Logger

Memory type	FLASH
Memory size	4 MB (10 000 records)
Minimum recording interval	1 s

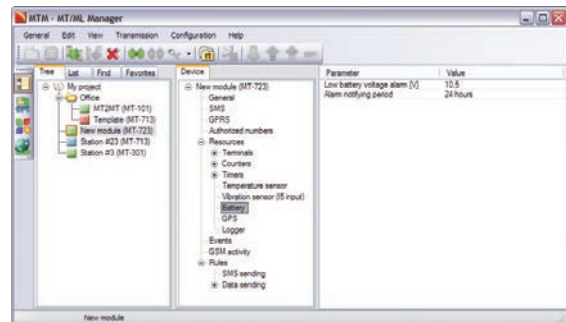
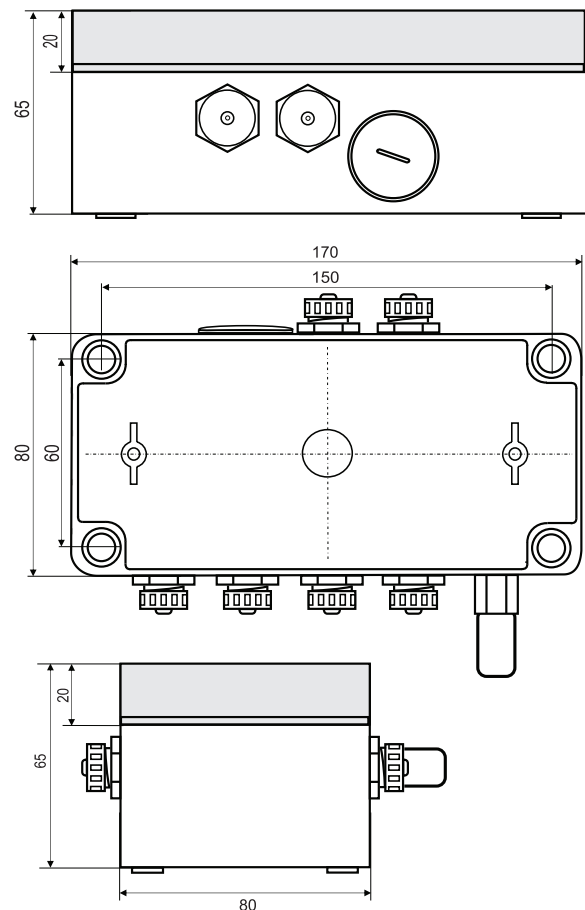
Configuration environment**Drawings and dimensions (all dimensions in millimeters)****Supplementary information:**

inventia

INVENTIA Ltd.

ul. Kulczyńskiego 14, 02-777 Warsaw, POLAND

tel.: +48 22 545-32-00, 545-32-01

fax: +48 22 643-14-21

inventia@inventia.pl, www.inventia.pl



INVENTIA complies with ISO 9001:2008 certified Quality Management System!
This project is co-financed by EUROPEAN UNION
from the European Regional Development Fund resources.