

- GSM/GPRS packet transmission
- Integral GSM 850/900/1800/1900 modem
- Autonomous login into GSM/GPRS network
- 8 opto-isolated binary/counter inputs
- 2 opto-isolated binary outputs
- AUDIO output for standard Intercom
- Capability of replaying recorded voice announcements
- Automatic alarm transmission upon activation of ALARM input (SMS/GPRS)
- Automatic reception of incoming voice calls, call back function
- Automatic confirmation of performed voice connections
- Optional communication port for monitoring and diagnostics of peripheral equipment (RS-232, RS-485)
- Support for MicroSD memory card
- Detachable terminals

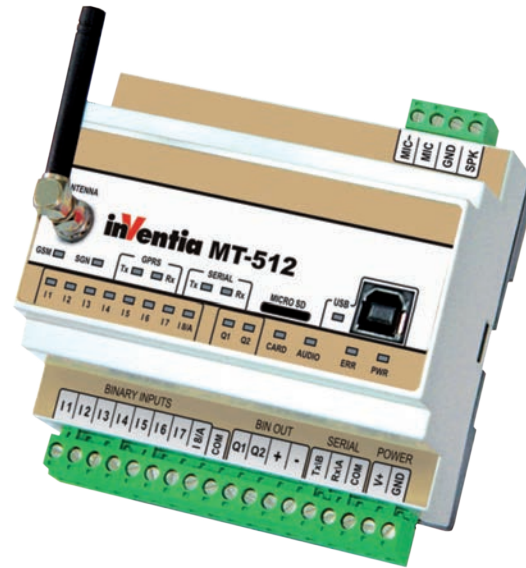

The MT-512 Specialized Alarm Module for lifts is a dedicated device compliant with the standard EN81-28:2003 "Remote alarm on passenger and goods passenger lifts" harmonized with the Lift Directive 95/16/EC.

The module monitors 8 binary inputs, controls 2 outputs, can establish a voice connection with Service Center and reply recorded messages. Optionally, the module can be equipped with RS-232 or RS-485 communication port for monitoring and diagnostics of peripheral equipment.

Thanks to employed wireless GSM/GPRS transmission the module is an ideal solution for applications where there are no phone landlines or where optimizing of reliability and reducing costs of monitoring systems is desired.

Compact design, integral GSM/GPRS modem, carefully selected technical parameters, interfacing elevator's standard Intercom make MT-512 an optimal choice for new installations as well as an upgrade during maintenance of existing elevators.

### Resources

- 1 dedicated, opto-isolated alarm input with adjustable time of insensitivity for repetitive activations
- 7 opto-isolated binary/counter inputs
- 2 opto-isolated controlling outputs
- AUDIO output adapted for standard Intercom
- Optional RS-232 or RS485 serial port for peripheral equipment (monitoring, diagnostics)
- Flash memory for configuration data, remotely updateable
- Additional external memory (MicroSD card)
- RTC real time clock

### Functionality

- Communication methods
  - GPRS - packet transmission
  - SMS
  - AUDIO
- Unsolicited messaging upon ALARM input activation, on state change on binary input or according to a schedule.
- SMS messaging upon ALARM input activation, on state change on binary input or according to a schedule.
- Programmatically set insensitivity time for ALARM input in order to prevent sending multiple alarms on the same event by repetitive activation of ALARM button.
- Programmable filtration constant for binary inputs
- Automatic confirmation of performed voice connection
- Data transmission from/to devices connected to communication port (optional)
- Remote configuration of parameters
- Access control based on authorized IP and phone numbers list with optional password protection
- User friendly configuration tool
- Easy integration with Service Center software
- LED diagnostics (status, GSM activity, GPRS activity, communication port activity, binary inputs and outputs state, active voice connection, MicroSD card errors detected)
- Detachable terminals
- Power supply 9-30V DC
- DIN rail mounting

**General**

Dimensions (length x width x height)	105x86x58 mm
Weight	300 g
Mounting	DIN Rail 35mm
Operating temperature	-20 ... +50°C
Protection class	IP40

**GSM/GPRS Modem**

Modem type	CINTERION
GSM	QuadBand (850/900/1800/1900)
Frequency range:	
GSM 850	Transmitter: 824MHz – 849 MHz Receiver: 869 – 894 MHz
EGSM 900	Transmitter: 880MHz – 915 MHz Receiver: 925 – 960 MHz
DCS 1800	Transmitter: 1710MHz – 1785 MHz Receiver: 1805 – 1880 MHz
PCS 1900	Transmitter: 1850 – 1910 MHz Receiver: 1930 – 1990 MHz
Sender's peak power GSM850/EGSM900	33 dBm (2W) - class 4 station
Sender's peak power DCS1800/PCS1900	30 dBm (1W) - class 1 station
Modulation	0,3 GMSK
Channel spacing	200 kHz
Antenna	50Ω

**Power supply**

DC (12V, 24V)	9 ... 30 V	
Input current (A) (for 12V DC, battery charged)	Idle	Max
	0,06	0,50

**Inputs I1...ALARM/I8**

Input voltage range	-30 ... 30 V
Input resistance	5,4 kΩ
Input voltage ON (1)	> 9V or < -9V
Input voltage OFF (0)	-3 ... 3V

**Outputs Q1,Q2**

Input voltage range	0 ... 30 V
Recommended mean current for single output	50 mA
Single output current	350 mA max.
Average current for all outputs	400 mA max.
Voltage drop for 350 mA	< 3,5 V max.
Current in off state	< 0,2 mA max.

**Application example**

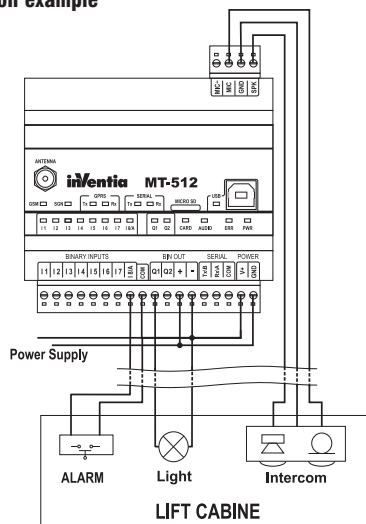

**Configuration environment**

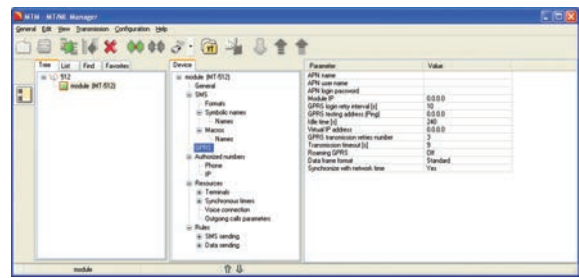

**Drawings and dimensions (All dimensions in millimeters)**

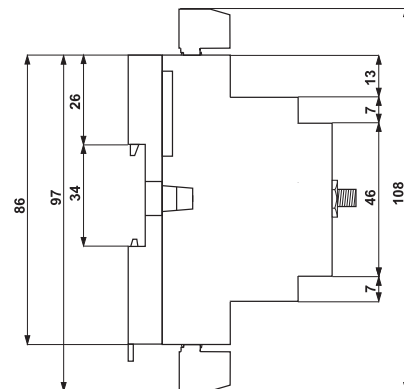
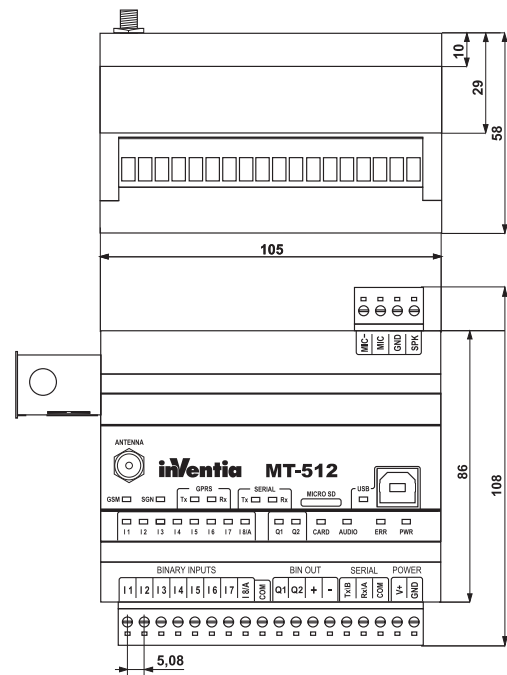

**Supplementary information:**



INVENTIA Sp. z o.o.  
ul. Kulczyńskiego 14, 02-777 Warszawa, POLAND  
tel.: +48 22 545-32-00, 545-32-01, fax: +48 22 643-14-21  
www.inventia.pl, inventia@inventia.pl



INVENTIA complies with ISO 9001:2008 certified Quality Management System!  
This project is co-financed by EUROPEAN UNION  
from the European Regional Development Fund resources.