

- Specialized module for vehicle tracking and monitoring
- Integral, 50 channels GPS module with highest sensitivity (-162 dBm) in SuperSense® technology
- Integral, 4-band, GSM modem
- Binary inputs and outputs
- Efficient fuel measuring
- Driver identification
- Large data recorder 30k records
- 2 serial ports (one RS485\*)
- 3 axis accelerometer
- Audio input and output\*

\* optional



ML-231 is a specialized telemetry module dedicated to monitor status and location of vehicles. Module's design is based on latest GPS/GSM technologies securing precision of localization and GSM signal propagation. The design complies with automotive industry design standards.

### Resources

- 5 binary inputs including:
  - dedicated ignition ON detection
  - dedicated alarm detection input
  - 2 general purpose binary inputs (with counting function)
  - 1 ground sensitive binary input
- 2 binary outputs
- 2 voltage analogue inputs
  - average value computing
  - max value detection
  - differential measurement
  - voltage measuring with alarm thresholds
  - precise fuel level measuring
- Main supply input with voltage monitoring
- Auxiliary supply with voltage monitoring
- 2 1-Wire inputs (Dallas iButton) for driver identification and temperature measuring
- Audio input & output (for loudspeaker and microphone)\*

### Functionality

- Cyclical position calculation on GPS signal base
- Monitoring of analogue and binary inputs and outputs
- Monitoring of fuel level and rapid level falls
- Speed monitoring/speeding/stopping

- Binary inputs signal filtration eliminates signal interference
- Additive or subtractive pulse counting on I3 and I4 inputs allows variable flow meter connections.
- Controlling binary outputs according to internal logic and remote commands
- Detection of missing GPS signal
- Reporting according to defined distance and time criteria as well as driving direction change
- Transmission of information as a result of triggering predefined event
- Logging of data in case of missing GSM communication
- Transmission modes
  - SMS
  - e-mail
- Configurable transmission in home network and in roaming
- Dynamic SMS composing allowing transmission of current measurements values
- Configurable SMS limits
- Local or remote configuration via GPRS
- Configurable access permissions – list of authorized IP addresses and phone numbers
- Monitoring of main and auxiliary supply voltage
- Diagnostic LED facilitating module's start
- Detachable connector and antenna sockets
- Dedicated local connection socket for PC for configuration and verification of parameters.
- 3-axis acceleration measurement
  - motion detection
  - collision detection (with 60 seconds log\*)

\* optional

**General**

Dimensions (length x width x height)	112x65x23,5 mm
Weight	110 g
Mounting mode	Velcro/Strap
Operating temperature	-20 ... +55°C
Protection class	IP40

**GSM/GPRS Modem**

Modem type	LEON G100
GSM	Quad band (850/900/1800/1900)
GPRS class	10
Antenna	50Ω SMA socket

**GPS Receiver**

Receiver type	μblox NEO-6
Sensitivity	-162 dBm Super Sense® Indoor GPS
Channel number	50
Antenna	Active 3V MCX connector

**Power supply**

DC voltage	9 ... 30 V		
Input current (mA) (for 13,8 V)	Max 200	Idle 35	Power Save < 10
Input current (mA) (for 27 V)	Max 100	Idle 20	Power Save < 10

**Inputs I1...I5**

Input voltage range	0 ... 30 VDC
Input resistance	22 kΩ
Input voltage ON (1)	> 7 V
Input voltage OFF (0)	< 2,5 V
Frequency range in counter mode (I3, I4)	50 Hz
Minimum pulse width "1"	20 ms

**Output 1, 2**

Recommended average current for single output	250 mA
Voltage drop at 250mA	0,3 V
OFF current	20 μA
Application	Immobilizer, parking mode, LED/BUZZER signalling, others

**Input 1-Wire 1, 2**

Standard	Dallas I-Button
Application	driver authorization temperature measurement

**Analogue Inputs**

Measurement range	0..10 V*
Input Resistance	200 kΩ
A / D converter	12 bits

\*with the possibility to increase the scope

**Serial ports**

Standard	RS-TTL (3 V)
Optional	RS-485
Application	External expansion modules (CAN, RFID)

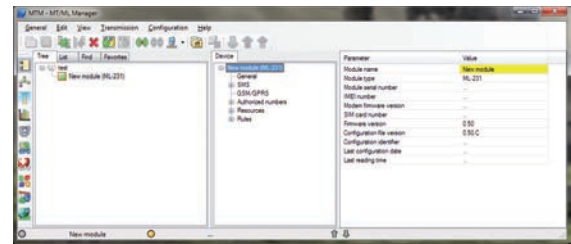
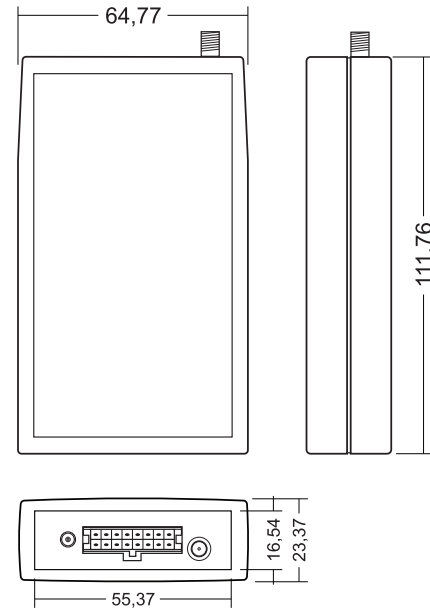
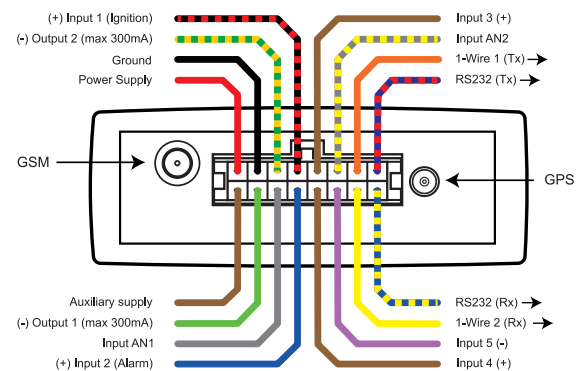
**Configuration program****Drawings and dimensions (all dimensions in millimeters)****Connections****Supplementary information:**

# inventia

INVENTIA Ltd.

ul. Kulczyńskiego 14, 02-777 Warszawa, POLAND

tel.: +48 22 545-32-00, 545-32-01

fax: +48 22 643-14-21

inventia@inventia.pl, www.inventia.pl



INVENTIA complies with ISO 9001:2008 certified Quality Management System!  
This project is co-financed by EUROPEAN UNION  
from the European Regional Development Fund resources.